

# DESIGN NOTES

## Using a Differential I/O Amplifier in Single-Ended Applications

Design Note DN473

Glen Brisebois

### Introduction

Recent advances in low voltage silicon germanium and BiCMOS processes have allowed the design and production of very high speed amplifiers. Because the processes are low voltage, most of the amplifier designs have incorporated differential inputs and outputs to regain and maximize total output signal swing. Since many low-voltage applications are single-ended, the questions arise, “How can I use a differential I/O amplifier in a single-ended application?” and “What are the implications of such use?” This Design Note addresses some of the practical implications and demonstrates specific single-ended applications using the 3GHz gain-bandwidth LTC6406 differential I/O amplifier.

### Background

A conventional op amp has two differential inputs and an output. The gain is nominally infinite, but control is maintained by virtue of feedback from the output to the negative “inverting” input. The output does not go to infinity, but rather the differential input is kept to zero (divided by infinity, as it were). The utility, variety and beauty of conventional op amp applications are well documented, yet still appear inexhaustible. Fully differential op amps have been less well explored.

Figure 1 shows a differential op amp with four feedback resistors. In this case the differential gain is still nominally infinite, and the inputs kept together by feedback, but this is not adequate to dictate the output voltages. The reason is that the common mode output voltage can be anywhere and still result in a “zero” differential input voltage because the feedback is symmetric. Therefore, for any fully differential I/O amplifier, there is always another control voltage to dictate the output common mode voltage. This is the purpose of the  $V_{OCM}$  pin, and explains why fully differential amplifiers are at least 5-pin devices (not including supply pins) rather than 4-pin devices. The differential gain equation is  $V_{OUT(DM)} = V_{IN(DM)} \cdot R2/R1$ . The common mode output voltage is forced internally to

the voltage applied at  $V_{OCM}$ . One final observation is that there is no longer a single inverting input: both inputs are inverting and noninverting depending on which output is considered. For the purposes of circuit analysis, the inputs are labeled with “+” and “-” in the conventional manner and one output receives a dot, denoting it as the inverted output for the “+” input.

Anybody familiar with conventional op amps knows that noninverting applications have inherently high input impedance at the noninverting input, approaching  $G\Omega$  or even  $T\Omega$ . But in the case of the fully differential op amp in Figure 1, there is feedback to both inputs, so there is no high impedance node. Fortunately this difficulty can be overcome.

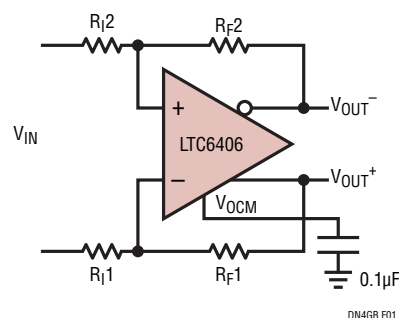

Figure 1. Fully Differential I/O Amplifier Showing Two Outputs and an Additional  $V_{OCM}$  Pin

### Simple Single-Ended Connection of a Fully Differential Op amp

Figure 2 shows the LTC6406 connected as a single-ended op amp. Only one of the outputs has been fed back and only one of the inputs receives feedback. The other input is now high impedance. The LTC6406 works fine in this circuit and still provides a differential output. However, a simple thought experiment reveals one of the downsides

LT, LT, LTC, LTM, Linear Technology, the Linear logo and  $\mu$ Module are registered trademarks of Linear Technology Corporation. All other trademarks are the property of their respective owners.

of this configuration. Imagine that all of the inputs and outputs are sitting at 1.2V, including  $V_{OCM}$ . Now imagine that the  $V_{OCM}$  pin is driven an additional 0.1V higher. The only output that can move is  $V_{OUT-}$  because  $V_{OUT+}$  must remain equal to  $V_{IN}$ , so in order to move the common mode output higher by 100mV the amplifier has to move the  $V_{OUT-}$  output a total of 200mV higher. That's a 200mV differential output shift due to a 100mV  $V_{OCM}$  shift. This illustrates the fact that single-ended feedback around a fully differential amplifier introduces a noise gain of two from the  $V_{OCM}$  pin to the "open" output. In order to avoid this noise, simply do not use that output, resulting in a fully single-ended application. Or, you can take the slight noise penalty and use both outputs.

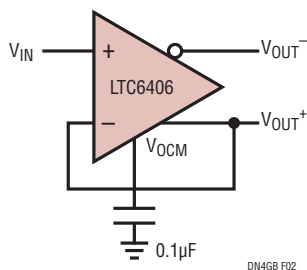

**Figure 2. Feedback Is Single-Ended Only. This Circuit Is Stable, with a Hi-Z Input Like the Conventional Op Amp. The Closed Loop Output ( $V_{out+}$  in This Case) Is Low Noise. Output Is Best Taken Single-Ended from the Closed Loop Output, Providing a 3db Bandwidth Of 1.2ghz. The Open Loop Output ( $V_{out-}$ ) Has a Noise Gain Of Two From  $V_{ocm}$ , But Is Well Behaved to About 300mhz, Above Which It Has Significant Passband Ripple.**

### A Single-Ended Transimpedance Amplifier

Figure 3 shows the LTC6406 connected as a single-ended transimpedance amplifier with  $20k\Omega$  of transimpedance gain. The BF862 JFET buffers the LTC6406 input, drastically reducing the effects of its bipolar input transistor current noise. The  $V_{GS}$  of the JFET is now included as an offset, but this is typically 0.6V so the circuit still functions well on a 3V single supply and the offset can be dialed out with the 10k potentiometer. The time domain response is shown in Figure 4. Total output noise on 20MHz bandwidth measurements shows  $0.8mV_{RMS}$  on  $V_{OUT+}$  and  $1.1mV_{RMS}$  on  $V_{OUT-}$ . Taken differentially, the transimpedance gain is  $40k\Omega$ .

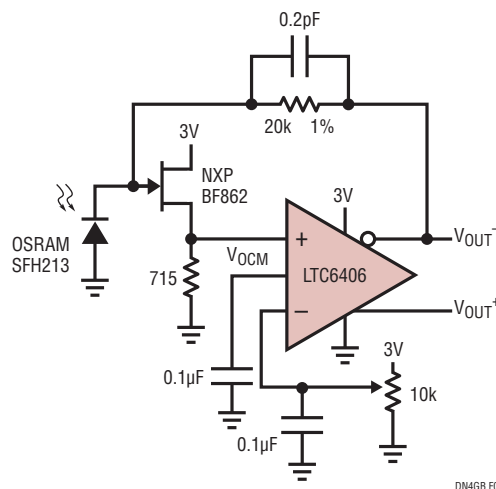

**Figure 3. Transimpedance Amplifier. Ultralow Noise JFET Buffers the Current Noise of the Bipolar LTC6406 Input Trim the Pot for 0V Differential Output under No-Light Conditions.**

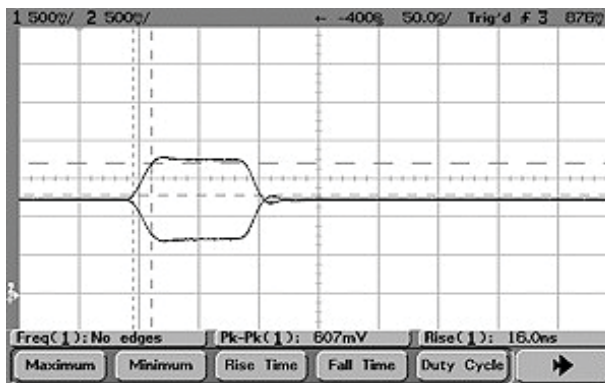

**Figure 4. Time Domain Response of Circuit of Figure 3, Showing Both Outputs Each with  $20k\Omega$  of TIA Gain. Rise Time is 16ns, Indicating a 20MHz Bandwidth.**

### Conclusion

New families of fully differential op amps like the LTC6406 offer unprecedented bandwidths. Fortunately, these op amps can also function well in single-ended and 100% feedback applications.

[Data Sheet Download](#)

[www.linear.com](http://www.linear.com)

For applications help,  
call (408) 432-1900, Ext. 3755

**Linear Technology Corporation**  
1630 McCarthy Blvd., Milpitas, CA 95035-7417  
(408) 432-1900 • FAX: (408) 434-0507 • [www.linear.com](http://www.linear.com)

dn473 LT/TP 1209 116K • PRINTED IN THE USA

**LINEAR**  
TECHNOLOGY  
© LINEAR TECHNOLOGY CORPORATION 2009